

August 21, 2020

Mr. Jorge Alfonso
TOWERS AT KEY BISCAIYNE
 1121 Crandon Blvd.
 Key Biscayne, FL 33149



Subject: Pool Repairs / Resurfacing

Dear Mr. Alfonso:

We are pleased to present our Budget Proposal for the design and construction of the Pool Repairs in Key Biscayne. Presented below is our understanding of the work required, based on Drawings and specification by PMM dated 5-20-19 and understanding of the scope.

INDEX OF DRAWINGS:	
T-0.0	TITLE SHEET
S-1.0	SCOPE OF SERVICES, REPAIR LEGEND AND DETAILS.
S-2.0	LOCATION AND POOL FLOOR PLANS.

SCOPE OF WORK AS PER THE BID FORM:

POOL RESURFACING/REPAIR PROJECT

- 1. General Conditions: **\$28,000.00**
- 2. Mobilization & Demobilization: **\$10,000.00**
- 3. Resurfacing of Pool: **\$ 158,477.00**
- 4. Repairs to Pool: **\$ 94,500.00**

Grand Total: \$290,977.00

UNIT PRICES

Repair Type I or II \$135.00 /Sq. Ft.

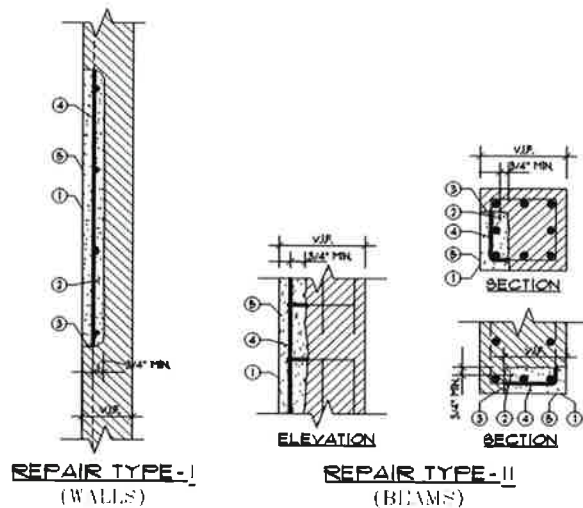

Bidder understands that the quantities of the repairs to the pool provided may be increased or decreased as needed as the project progresses. The additive/deductive prices for the types of repairs are as follows:



EXCLUSIONS:

- Cost of payment and performance bond.
- Cost of Permit fees, permit processing, impact fees, and expediting.
- Asbestos and/or lead abatement.
- Fireproofing and/or fire sprinklers.
- Removal and/or relocation of any unforeseen installations that interfere with the above described work.
- Additional upgrades of existing building to meet current code.
- Plumbing and/or Storm drainage installations.
- Pool safety barrier.
- Any other items not delineated in this proposal.

Thank you for affording us the opportunity to present you with this budget proposal for the construction of your project. We will follow-up once you have had a chance to review so we can clarify any questions and discuss next steps.

Sincerely,

A handwritten signature in blue ink, appearing to read 'Jorge Zubimendi'.

Jorge Zubimendi
Director of Estimating – GC Division
Florida Lemark Corporation